



OFI

Marta Pálmaiová

Hudobná výchova

Pracovný zošit 3



3



Expert Školského Ústavu:
Krcsmériné Gyurkovics Mária
Nagy Károly

Lektor:
Kálmán Vikol
Katarína Noszlopyová

Grafika:
László Urmai

Obálka:
Korda Ágnes

© Pálmainé Pápay Márta, Oktatáskutató és Fejlesztő Intézet (Nemzedékek Tudása Tankönyvkiadó Zrt.), 2015



A projekt az Európai Unió támogatásával, az Európai Szociális Alap társfinanszírozásával valósul meg. A tankönyv megfelel az OM kerettantervének 28/2000.(IX.21.).

ISBN 978 963 19 7694 6

Vysvetlenie znakov



Kreslite rytmus.



Vytlieskajte rytmus.



Kreslite noty.



Vyriešte hádanky.



Vymyslite,
spievajte melódiu.



Pokračujte v zošite.

Cvičenie rytmu a písanie nôt

Taktová čiara



Doplňte taktové čiary, potom rytmus vytlieskajte.



Tlačiarenský škriatok ukradol niektoré rytmické hodnoty. Doplňte ich.

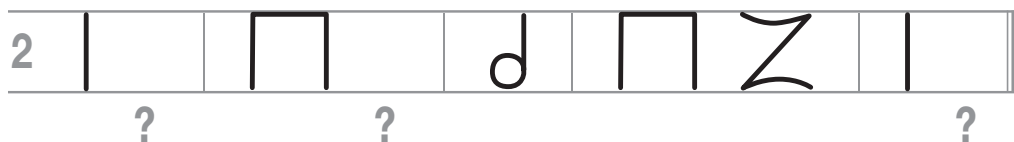

Doplňte chýbajúce solmizačné slabiky.

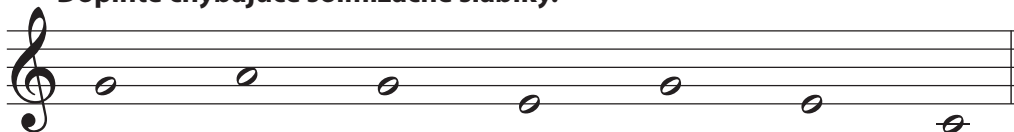

s

Doplňte noty podľa solmizačných slabík. **D** bude v prvej medzere. Melódiu aj zaspievajte pomocou značiek rúk (fonogestiky).

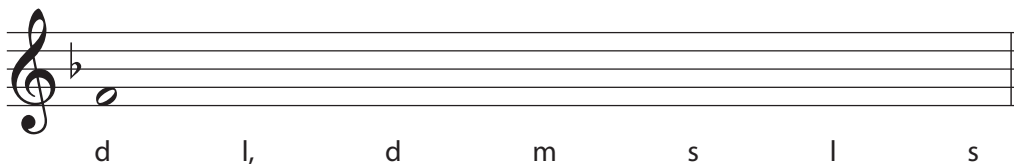



**Vypracujte cvičenie. Spoznali ste pieseň z učebnice?
Zaspievajte ju aj solmizačnými slabikami.**

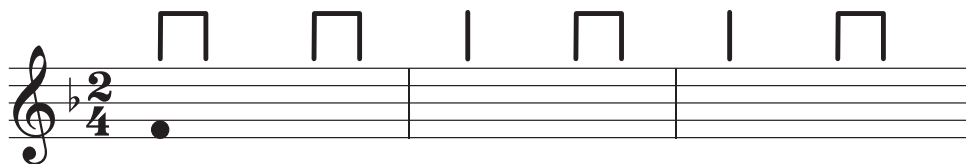

d r m d s m r s m r

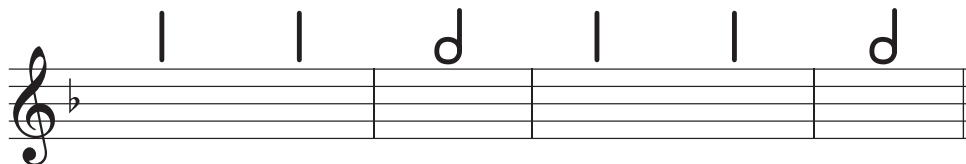

s m r m r d

Na základe predošlého cvičenia na notovú osnovu doplňte noty a potom aj rytmus na základe solmizačných slabík. Tam, kde sú noty, napíšte solmizačné slabiky.

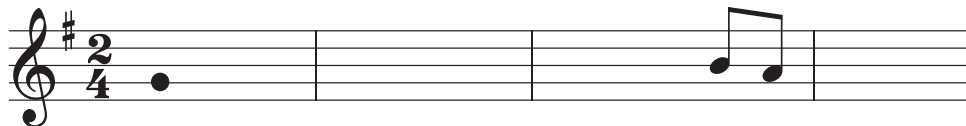

m s s s s s s s s m d

Skúste samostatne vymyslieť rytmus štyroch taktov. Nový rytmus vytlieskajte.



Osminová nota a pomlčka

Píšte osminovú notu na notovú osnovu podľa vzoru.

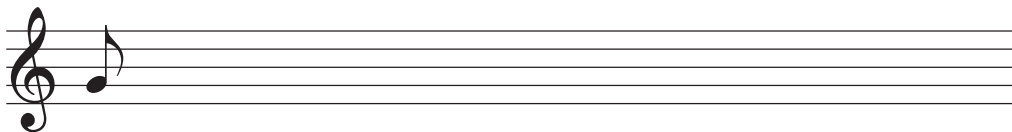

Pokračujte podľa príkladu. Osminová nota je teraz v medzere.

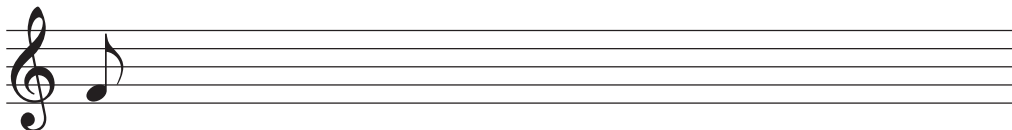

Pozor, nad 3. čiarou nožička bude smerom dolu.

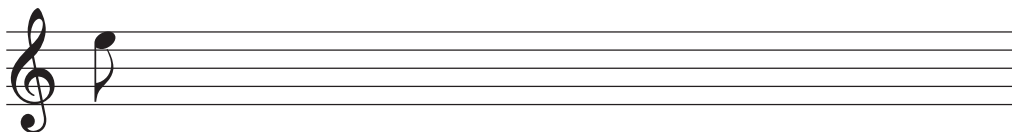

Pozor, nota je na 4. čiare, nožička sa píše smerom dolu.

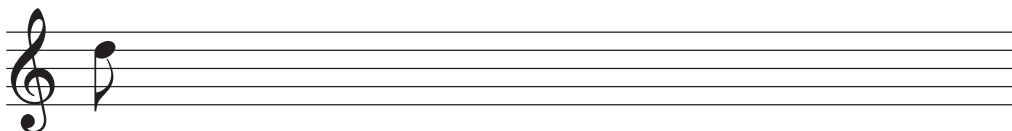

Pokračujte podľa príkladu.

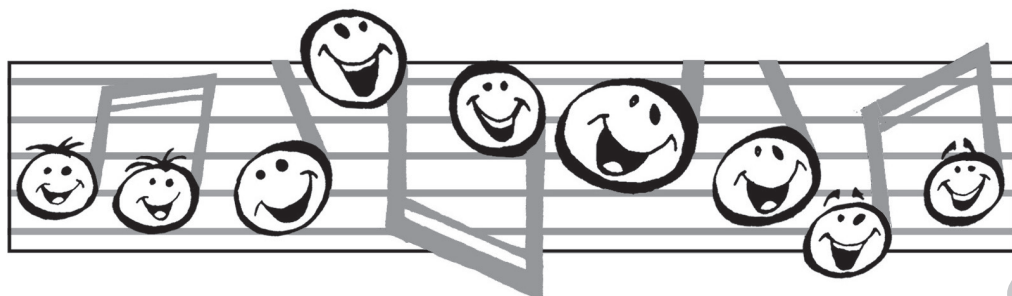
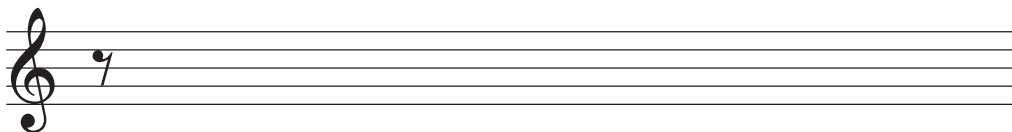



Na základe príkladu nakreslite osminovú notu s pomlčkou na čiaru.

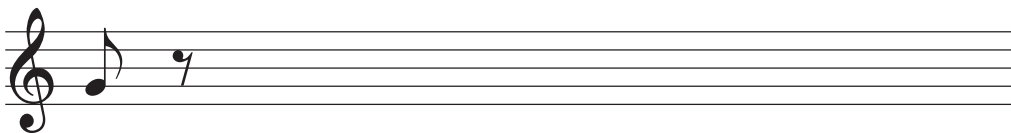

Pozor, osminová nota je teraz v 4. medzere.

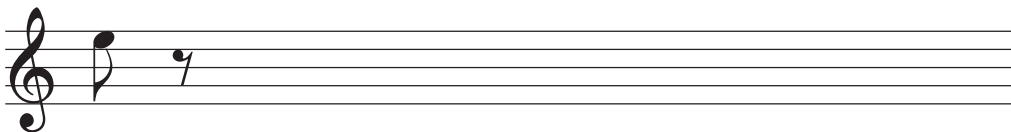

Osminové noty môžeme písať aj tak, že sú spojené vo dvojiciach. Už ste sa s nimi stretli pri rytmických cvičeniach.

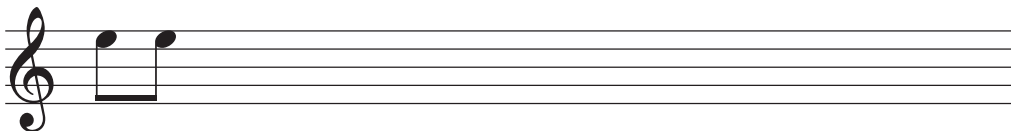
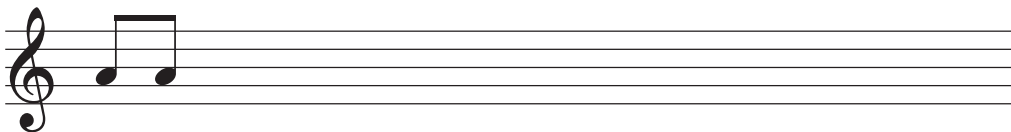

Skúste sami vypracovať štyri dvojdobé takty, použite aj známe osminové noty a pomlčky. Potom cvičenie vytlieskajte.

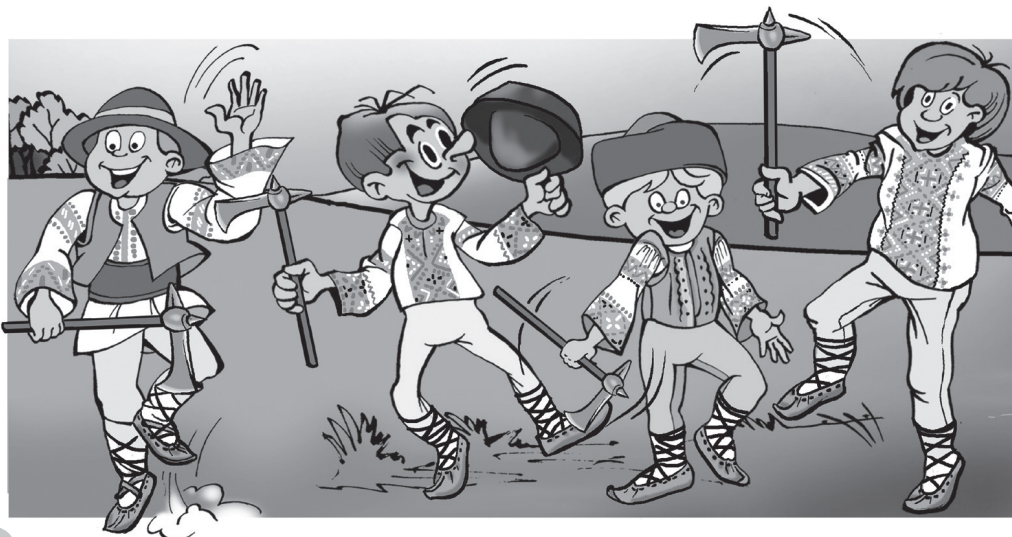
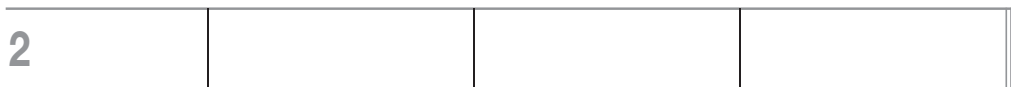

Zapíšte rytmus riekanky z učebnice (strana 12.). Píšte presne nad slabiky.



2			
---	--	--	--

Ža- lo- val sa u- te- rá- čik za- ve- se- ný na skri- ni,

2			
---	--	--	--

že ho Jan- ko kaž- dý ve- čer ru- čič- ka- mi za- špi- ní.

Zapíšte melódiu riekanky z učebnice podľa solmizačných slabík. Noty píšte presne nad slabiky.

<p>Ža- lo- val sa u- te- rá- čik za- ve- se- ný na skri- ni,</p> <p><i>D m s s s l s m s s m m r r r</i></p>			

Vytlieskajte rytmus vyčítanky. Samostatne vymyslite pre ňu melódiu so známymi solmizačnými slabikami.



--	--	--	--

E- de- den, be- de- den štet- ka hre- beň

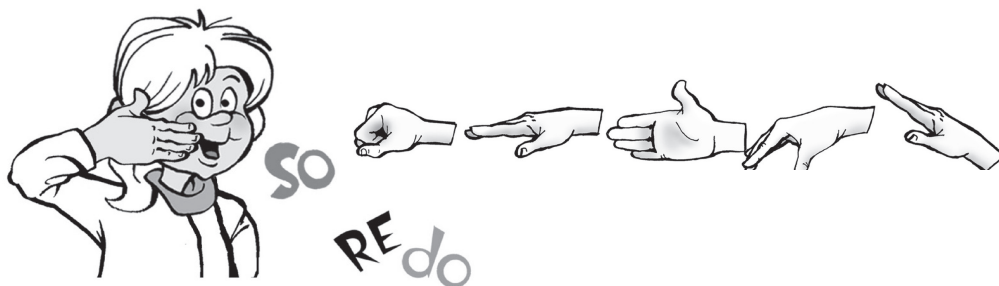

Rytmické a solmizačné cvičenia



Tlačiarský škriatok nám zasa ukradol niektoré rytmické hodnoty. Doplňte ich.

2 | | ♪ Z ♪ Z | | ♫

? ? ?

2 ♫ ♪ | | | ♪ | ♪ ♫ |

? ? ?

2 Z ♪ | | | | Z ♫

? ? ? ? ?



Tu nám škriatok ukradol niektoré noty. Doplňte ich pomocou solmizačných slabík.



s m d r m d l,

Doplňte chýbajúce solmizačné slabiky.

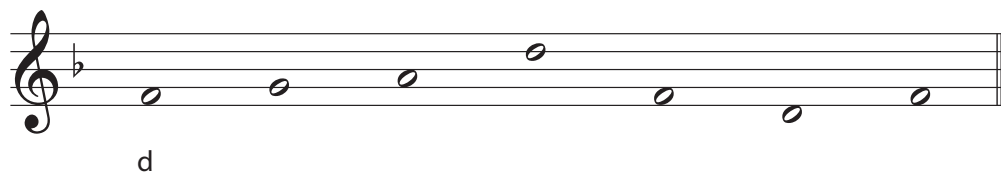

d

Cvičenia so spodným **s,**

Doplňte chýbajúce solmizačné slabiky.



d s,

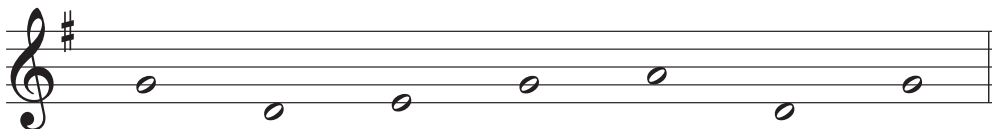

d s,

A teraz naopak, doplňte chýbajúce noty.

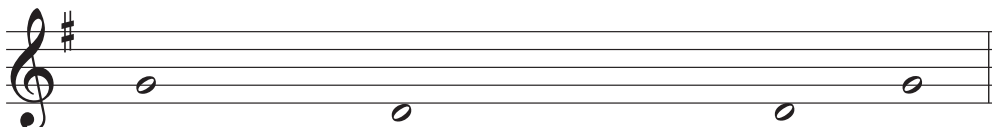

d l, s, d r s, d

Zaspievajte cvičenie pomocou rukoznačiek solmizačných slabík. Nezapadnite, že spodné **s,** a **l,** majú takú istú značku, iba ich ukazujeme nižšie.





Na základe solmizačných slabík napíšte melódiu na notovú osnovu. Kreslite noty prázdnu hlavičkou.

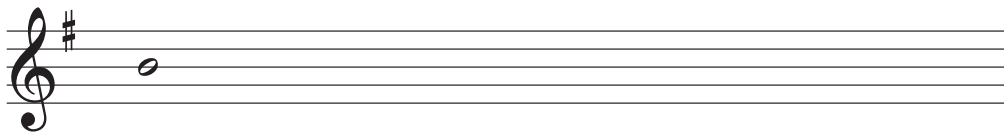

m r d l, s, l, d

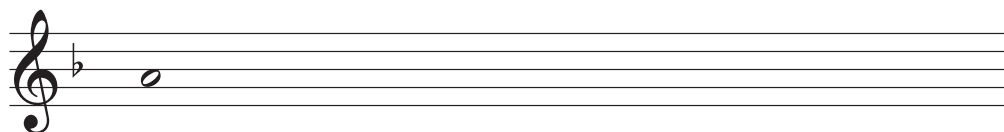

m d l, s, l,



Spievajte nápevy známych piesní aj pomocou tohto stĺpca.

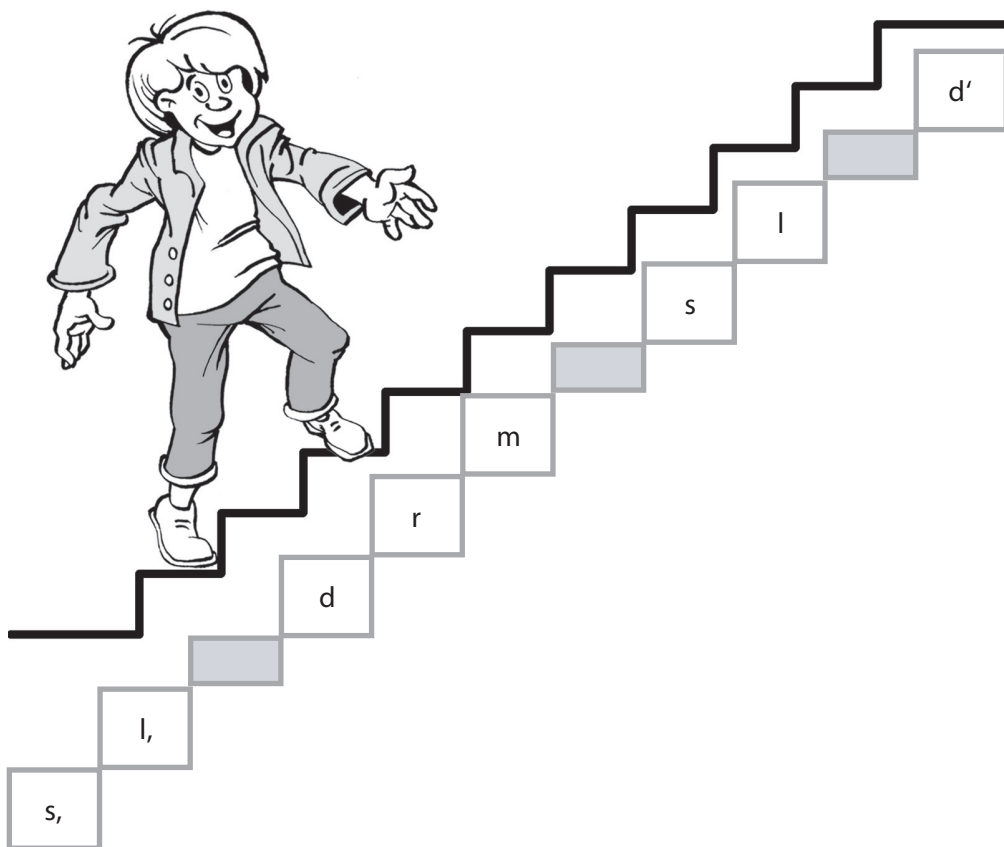

Kánony

Vypracujte rytmický kánon tak, že druhý hlas sami napíšete do voľného riadku. Začnite od druhého taktu. Potom rytmus aj vytlieskajte.



2 4		□ Z	□ 9 1	♩	—
2 4					

Teraz samostatne vymyslíte štyri takty rytmu. Prepíšete ich do druhého riadku ako kánon. Potom ich vytlieskajte vo dvojiciach.



2 4					—
2 4	—				

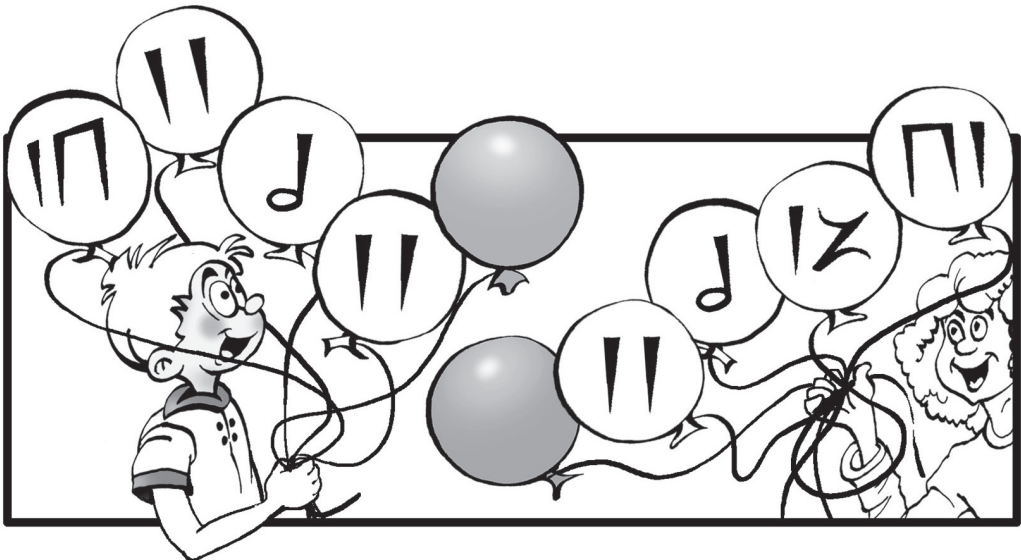

Cvičenia na štvordobý takt



Doplňte chýbajúci rytmus známej piesne *Bol jeden gajdoš*.

4 4		o o		
--------	--	-----	--	--

4 4	:		:	o	o o
--------	---	--	---	---	-----



Zahrajte sa na skladateľov a vymyslite rytmus podľa vlastnej fantázie.
Môžete použiť všetky rytmické hodnoty, ktoré už poznáte.

4 4				
--------	--	--	--	--

4 4				
--------	--	--	--	--

4 4				
--------	--	--	--	--



Písanie celej noty a pomlčky

Precvičte si písanie celej noty, ktorá bude na tretej čiare.

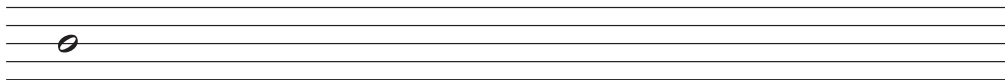

Napište jeden riadok celej noty, ktorá bude v druhej medzere.

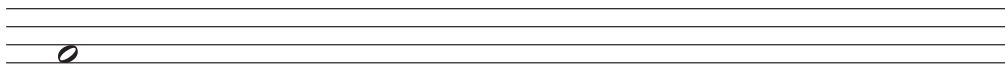

Napište jeden riadok celej noty, ktorá bude striedavo v tretej medzere a na štvrtej čiare.

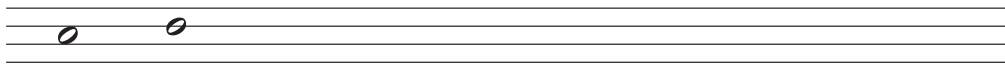

Precvičte si písanie celej pomlčky podľa návodu učiteľa.

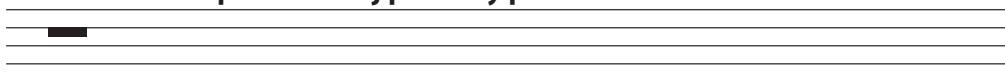

Precvičme si synkopu



Pokračujte podľa vzoru.

2	♩ ♩					
---	-------	--	--	--	--	--

Doplňte do prázdnych taktov synkopu. Potom cvičenie vytlieskajte.

2 4	♩ ♩		♩	♩ ♩ ♩		♩ ♩
--------	-------	--	---	---------	--	-------

Vymyslite podobné rytmy v dvojdobom takte.

2 4				
--------	--	--	--	--

Vymyslite podobné rytmy v štvordobom takte.

4 4				
--------	--	--	--	--

4 4				
--------	--	--	--	--



Hlvolamy pre zábavu

Ak ste pieseň spoznali, doplňte jej chýbajúce takty. Pomôžu vám solmizačné slabiky.



A musical staff in treble clef with a key signature of one sharp (F#). The first two measures contain notes: G4, A4, B4, C5 in the first measure, and D5, E5 in the second. The next two measures are empty. Below the staff, the syllables 'd | | s | | s' are written, corresponding to the notes above.

Ak ste ju spoznali, doplňte jej chýbajúce časti zo začiatku a konca piesne.

A musical staff in treble clef with a key signature of one sharp (F#) and a 2/4 time signature. The first measure contains notes: G4, A4, B4, C5. The second measure is empty. The third measure contains notes: D5, E5. The fourth measure contains a note: F#5. Below the staff, the syllable 'd' is written under the first measure.

Namiesto otázniky napíšte chýbajúci rytmus. Spoznali ste ktorá je to pieseň?

A rhythm exercise in 2/4 time. The staff shows a sequence of rhythmic patterns: two vertical lines (quarter notes), a square with a horizontal line across the top (half note), two vertical lines (quarter notes), two vertical lines (quarter notes), and two empty boxes. Below the staff, there are question marks: two under the second and third boxes, and four under the last two boxes.

Na základe rytmu spoznajte pieseň.

A rhythm exercise in 4/4 time. The staff shows a sequence of rhythmic patterns: four vertical lines (quarter notes), a note with a sharp sign (quarter note), two vertical lines (quarter notes), and a note with a flat sign (quarter note).

A rhythm exercise in 4/4 time. The staff shows a sequence of rhythmic patterns: four square notes with horizontal lines across the top (half notes), two vertical lines (quarter notes), and a note with a flat sign (quarter note).



Rytmické hodnoty, ktoré už poznáte

Celá nota



Polová nota



Štvrtová nota



Osminová nota



Celá pomlčka



Polová pomlčka



Štvrtová pomlčka



Osminová pomlčka

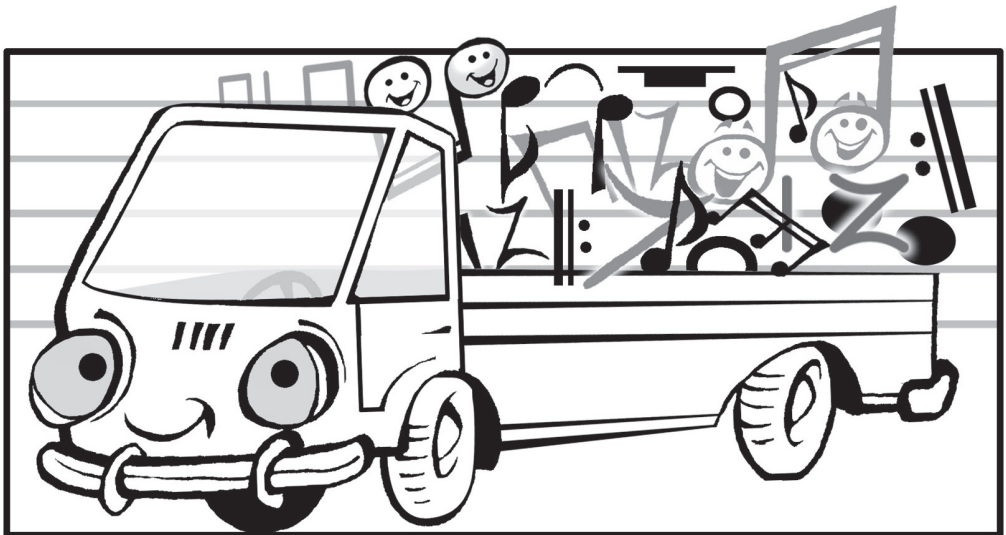

Precvičte si synkopu

Prečítajte slová nahlas. Vytlieskajte ich, potom zapíšte ich rytmus.



2 4				
--------	--	--	--	--

Ko - már- no vy - mý - šľaš po - čí - taš u - čiš sa

Vymyslite slová, ktoré majú rytmus synkopy. Zapište ich rytmus.

2				
---	--	--	--	--

2				
---	--	--	--	--

2				
---	--	--	--	--

Vytlieskajte rytmus riekanky z učebnice *Cicúška*. Zapište aj rytmus prvých riadkov.

2 4				
--------	--	--	--	--

Ci - cúš - ka, ma - cúš - ka, kde si bo - la?





Vypracujte rytmus riekanky z učebnice Kvá kvá kvačica.

2 4				
--------	--	--	--	--

Kvá, kvá, kva - či - ca, čier - na bie - la sle - pi - ca.

2 4				
--------	--	--	--	--

Pod sto - lom sú dro - bce, ku - ra vo - du slop - ce.



K známej riekanke teraz vymyslíte aj melódiu. Použite solmizačné slabiky

s, l, m, r, d.



# 2 4				
-------------	--	--	--	--

d

Kvá, kvá, kva - či - ca, čier - na bie - la sle - pi - ca.

#				
---	--	--	--	--

Pod sto - lom sú dro - bce, ku - ra vo - du slop - ce.

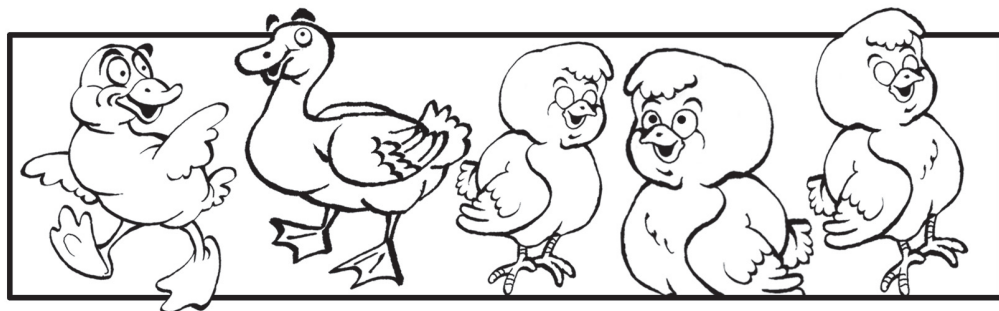

Napíšte rytmus tejto známej riekanky.



2 4				
--------	--	--	--	--

Za - sia - la som šo - šo - vič - ku, ne - chce - la mi rias - ti,

2 4				
--------	--	--	--	--

mu - se - la som kú - de - ľôč - ku na - dia - ti a prias - ti.

Na základe solmizačných slabík napíšte melódiu pre prvý riadok riekanky *Zasiala som šošovičku.*

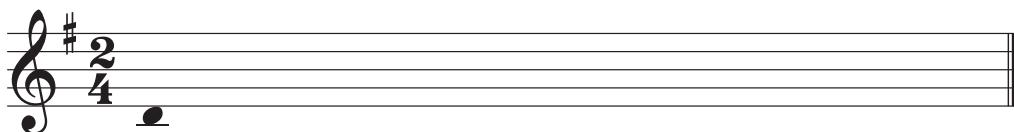

s, d d d d r m d r r r r m m

Druhý riadok riekanky skúste vypracovať samostatne. Rytmus dodržujte tak, ako v predošlých riadkoch.

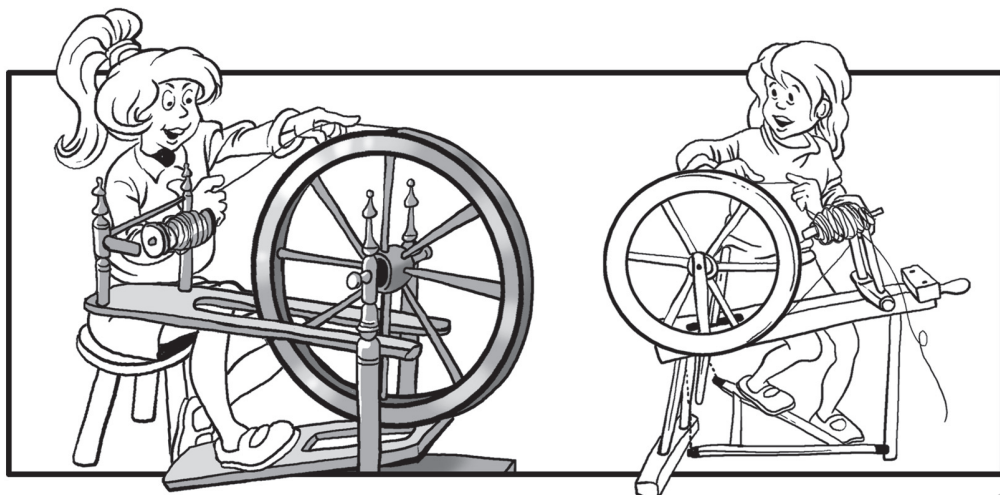
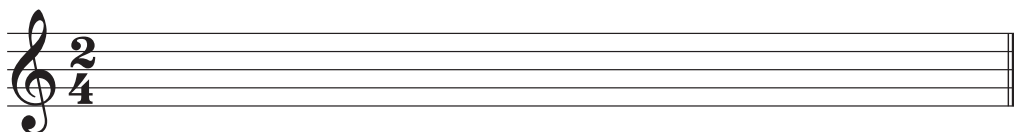

Cvičenia na horné d'



Spoznáte pieseň z učebnice(strana 35)? Doplňte chýbajúce solmizačné slabiky.



d

Doplňte chýbajúce solmizačné slabiky.



s



Skúste doplniť chýbajúce noty známej piesne z učebnice (strana 24), a potom dopíšete solmizačné slabiky.

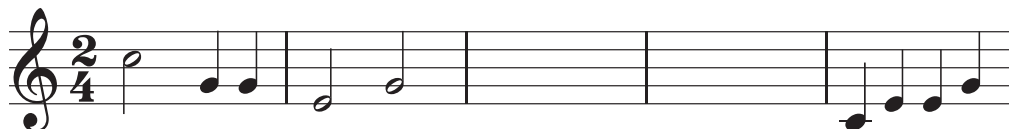

d'



Čo ste sa naučili tento rok?

Zopakujte si značky rúk. Pomocou nich zaspievajte úryvky známych piesní. Potom vymyslíte nové melódie.

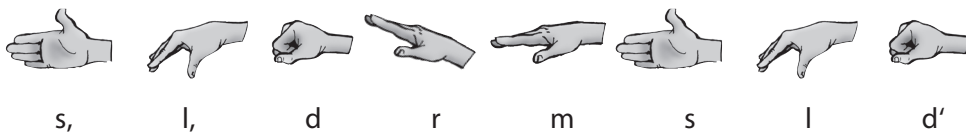

Zaspievajte si známu pieseň Zahrajte hudaci, potom zapíšte jej prvé tri takty melódie pomocou solmizačných slabík. Skúste úplne samostatne bez pomoci.

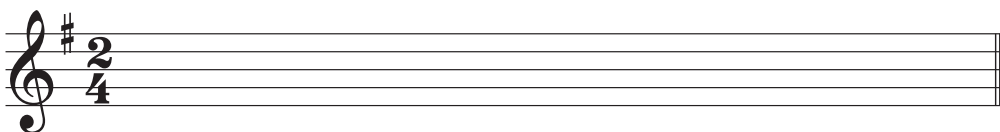

Tu sú všetky známe rytmické hodnoty:

celá nota – celá pomlčka



polová nota – polová pomlčka

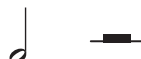

štvrtová nota – štvrtová pomlčka



osminové noty – osminové pomlčky



osminová nota – osminová pomčka



synkopa



Do prázdnych taktov napíšte všetky rytmické hodnoty.



Pre zábavu



Naučte sa túto riekanku, potom si ju aj vytlieskajte a samostatne zapíšte jej rytmus. Ak ju viete naspamäť, môžete sa ju aj zahrať pri zábavách na dvore, či v táboroch.

Učí žabiak deti spievať kvak, kvak, kvak.

Mama žaba prikyvuje tak, tak, tak.

Žaburienky spievajú, ústočká nadúvajú kvak, kvak, kvak.

Ale zrazu utíšil sa žabí hluk, blízko mláky zatrepotal čudný zvuk.

A keď bocian priletí, mama skríkne na deti: Ani muk!

2



Vertical line 1

Vertical line 2

Vertical line 3

Vertical line 4

Vertical line 5

Oktatáskutató és Fejlesztő Intézet
1143 Budapest, Szobránc u. 6–8.
Tel.: (+36-1) 235-5508
Fax: (+36-1) 235-7202
Vevőszolgálat: vevoszolgalat@ofi.hu

A kiadásért felel: dr. Kaposi József főigazgató
Raktári szám: NT-30440/M
Műszaki igazgató: Kamp Alfréd
Felelős szerkesztő: Sutyinszki Mária
Grafikai szerkesztő: Görög Istvánné
Műszaki szerkesztő: Orlai Márton
Terjedelem: 2,1 (A/5) ív
A tankönyv tömege: 70 gramm
1. kiadás, 2015
Nyomdai előkészítés: B&B Grafikai Stúdió Kft.